

# VACTIDY

## T8 Robot Vacuum Cleaner

# User's manual



- Please read this manual carefully before use
- The company reserves the right to interpret the instructions
- The appearance of the product is subject to change without notice.
- After reading, please keep it together with the invoice
- In case of product technology or software upgrade, without notice

T8

Shenzhen Jingwu Technology Co., Ltd.

Service support

Web: [www.vactidy.com](http://www.vactidy.com)

E-mail: [support@vactidy.com](mailto:support@vactidy.com)

## IMPORTANT SAFETY INSTRUCTIONS FOR HOME USE ONLY

Basic precautions should always be observed when using any electrical equipment, including the following:

### **WARNING:**

READ ALL SAFETY INSTRUCTIONS AND THE ENTIRE MANUAL. Failure to heed the warnings and instructions may result in electric shock, fire, or serious injuries. Please read all instructions before using this robot.

### **WARNING:**

- This robot is intended for children 8 years of age and older. People with reduced physical, sensory, or intellectual abilities, or those who lack experience and knowledge, should be supervised or instructed in safely using the robot; they must also be aware of possible hazards. Children should not play with this robot. Cleaning and user maintenance should not be performed by children without supervision.
- The robot must be used in accordance with the instructions in this manual. The company is not responsible for any damage or injury caused by improper use. To reduce the risk of injury or damage, please observe the following safety precautions when installing, using and maintaining the robot:
- Please read all instructions regarding safety and operation before using the robot.
- Keep the safety and user manual for future reference. If you accidentally lose the manual, you may visit the official website to download the electronic version. (<https://www.vactidy.com>).
- Heed all warnings on the robot, battery, charging station, and user manual.
- Follow all operating and usage instructions.



"  " The product's labels or packaging indicate that:

Do not dispose of the electrical appliances as unsorted waste or, use a separate waste collector.

Contact your local authority for information on the appropriate disposal method. If electrical appliances are discarded in landfills, hazardous substances can leach into groundwater, enter the food chain, and damage people's health. Contact your local or regional waste management agency for more information on their recycling and reuse programs.

## Restrictions

1. This robot is for indoor use only. Do not use it outside, or in commercial and industrial environments.
2. Before using the robot, remove fragile items such as clothing, loose-leaf paper, rope or curtains, and power cords from the floor. The robot may snag onto an object, table, or shelf if it gets stuck on a cable.
3. This robot is not a toy. Do not sit or stand on this robot. Children and pets should be supervised while the robot is operating.
4. Store and operate the robot at room temperature.
5. Do not use this robot to clean anything that is burning or smoking.
6. Do not use the robot to clean bleach, paint, or other chemicals, or anything wet.
7. If the cleaning area involves a balcony, a physical barrier should be set up to prevent the robot from accessing the balcony and ensure it operates safely.
8. People (including children) with reduced physical, sensory, or intellectual abilities, or those who lack experience and knowledge, should be supervised or instructed in safely using the robot.
9. Children should be supervised to ensure they do not play with the robot. Further, cleaning and maintenance must not be performed without adult supervision.
10. Do not place anything on the robot.
11. Please note the robot will move on its own. Try to be careful when walking in the operating area to avoid stepping on it.
12. Do not operate the robot in an area where a ground power outlet is exposed.

## Battery and Charging

1. Only use rechargeable battery packs with specifications approved by our company.
2. Use the standard complimentary charging base for charging. This product must not be used with any type of power adapter; the use of other power adapters will immediately void the warranty.
3. Do not use a charging station with a damaged power cord or plug. If the power cord or plug is damaged, it must be repaired by the manufacturer or a similarly qualified party.
4. Be sure to charge and remove the batteries in the robot and accessories before long-term storage or transportation.
5. The remote control battery type is AAA alkaline battery.
6. To replace the remote control's batteries, slide the battery cover on the back of the remote control open, remove the battery cover, and replace the batteries.
7. Charge the device indoors only.
8. Your robot's charging station may be protected by a surge protector to prevent power surges.
9. Do not operate the charging station with wet hands.
10. Before cleaning or maintaining the robot, the plug must be removed from the socket.
11. Ensure the voltage rating of the enclosed charging station matches the voltage of the standard outlet.
12. Used battery packs should be placed in a sealed plastic bag and disposed of safely in accordance with local environmental regulations.
13. Before each use, inspect the battery pack for signs of damage or leakage. Do not charge damaged or leaking battery packs.
14. If the battery pack leaks, please contact Customer Service.
15. The battery pack must be removed from the robot before disposal.
16. Do not crush or disassemble the battery pack. Do not apply heat to the battery pack or place it near any heat source.
17. Do not incinerate the battery pack. Do not short-circuit the battery pack.
18. Do not immerse the battery pack in any liquid.
19. Do not crush or disassemble the robot.

### FCC Compliance Statement

This device complies with Part 15 of the FCC Rules. Operation is subject to the following two conditions: (1) This device may not cause harmful interference, and (2) this device must accept any interference received, including interference that may cause undesired operation.

**Warning:** Changes or modifications not expressly approved by the party responsible for compliance could void the user's authority to operate the equipment.

**Note:** This equipment has been tested and found to comply with the limits for a Class B digital device, pursuant to Part 15 of the FCC Rules. These limits are designed to provide reasonable protection against harmful interference in a residential installation. This equipment generates, uses, and can radiate radio frequency energy and, if not installed and used in accordance with the instructions, may cause harmful interference to radio communications. However, there is no guarantee that interference will not occur in a particular installation. If this equipment does cause harmful interference to radio or television reception, which can be determined by turning the equipment off and on, the user is encouraged to try to correct the interference by one or more of the following measures: (1) Reorient or relocate the receiving antenna. (2) Increase the separation between the equipment and receiver. (3) Connect the equipment into an outlet on a circuit different from that to which the receiver is connected. (4) Consult the dealer or an experienced radio/ TV technician for help.

### FCC Radiation Exposure Statement:

This equipment complies with FCC radiation exposure limits set forth for an uncontrolled environment. This equipment should be installed and operated with minimum distance 20cm between the radiator & your body.

# Inside the Box

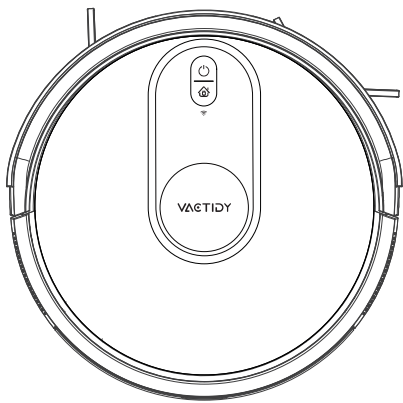

Robot

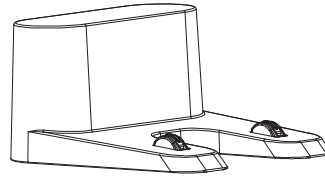

Charging Station

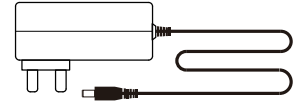

Adapter

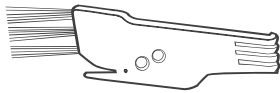

Cleaning Brush

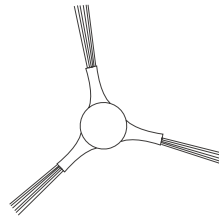

Side Brush



Remote Control

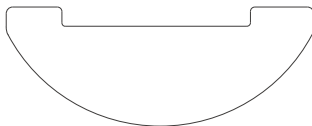

Mop Pad

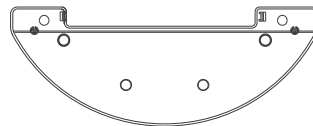

Mop Pad Holder

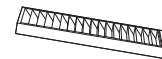

HEPA Filter

# Product Description

## The Robot

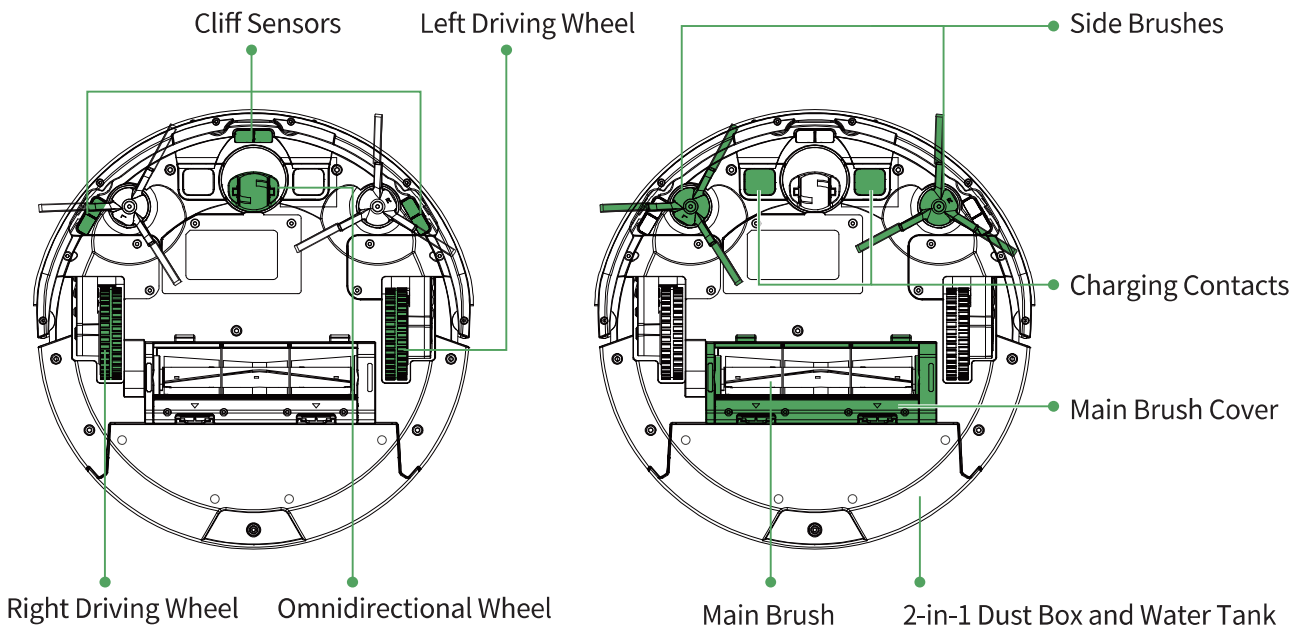
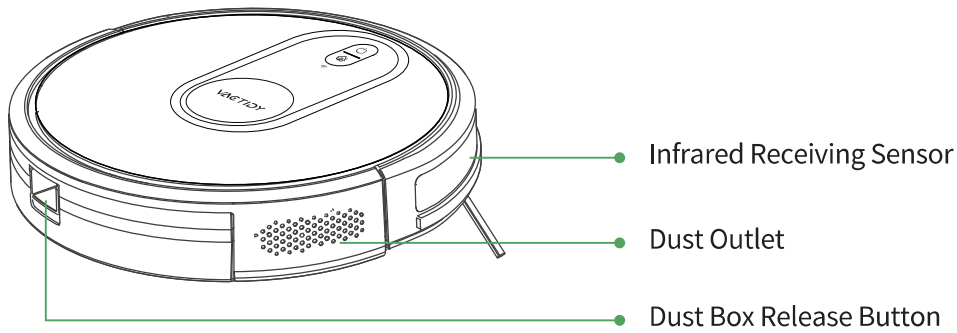
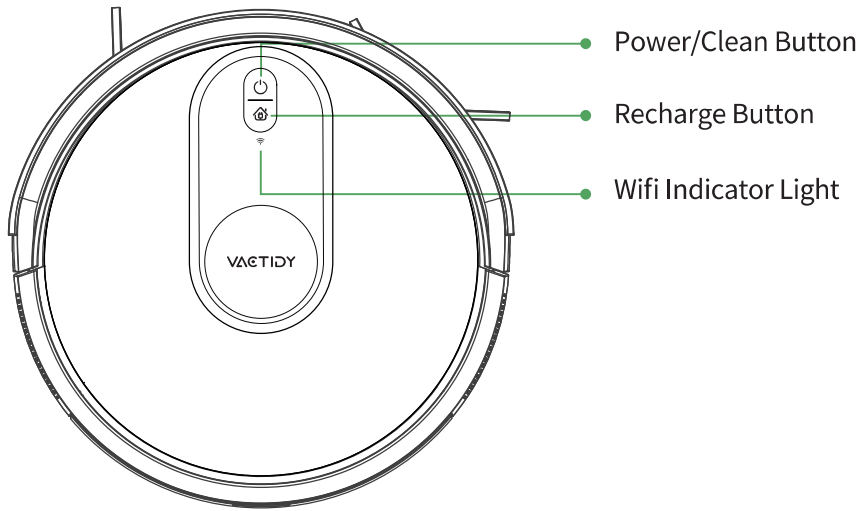

# Product Description

## Charging Station

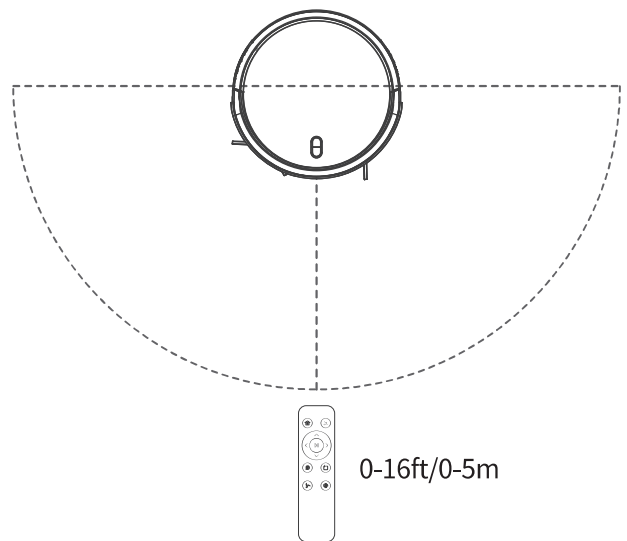
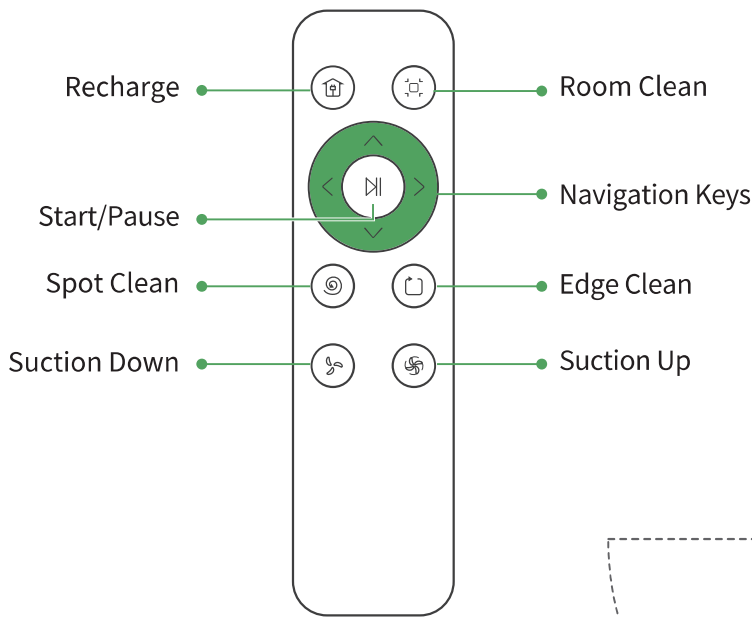
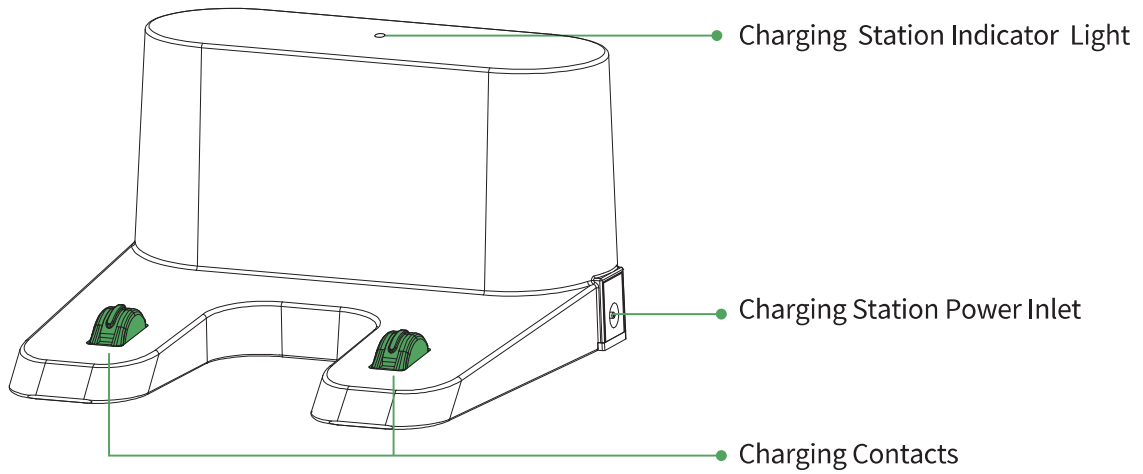



### Tips:

1. Install a pair of AAA batteries before using the remote controller. Ensure the correct polarity of batteries.
2. Make remote control point to the robot within an effective range of 0-16ft/0-5m.

# Product Description

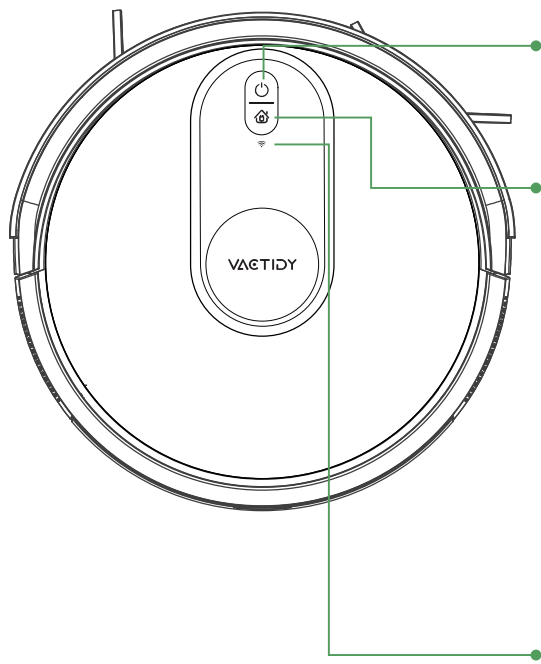
## Robot Indicator Lights



-  **Power button/Clean button**
  - Press and hold 3s to turn on/off.
  - Short press to start/pause cleaning.
-  **Recharge button/recharge & power indicator**

Press the button to return the robot to the charging station.

Press and hold the recharge and power buttons at the same time for 5s to enter network configuration mode.

**Flashing blue light:** Powering on/upgrading firmware.

**Solid blue light:** Standby/normal working state.

**Flashing yellow light:** Low battery/recharging.

**Flashing green light:** Charging.

**Solid green light:** Fully charged.

**Flashing red light:** Error state.
-  **Wifi indicator light/network configuration**

**Enter network configuration:** wifi indicator light flashes in white / solid white light indicates the network is successfully configured / wifi indicator light is off if network is not configured or network configuration fails.

## Charging Station Indicator Light

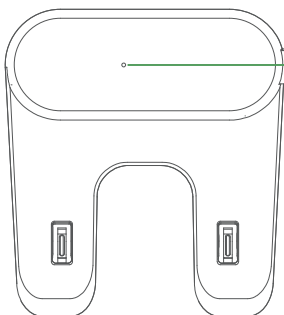

The white light indicates the robot is powered on



# Product Operation

## Cleaning Suggestions

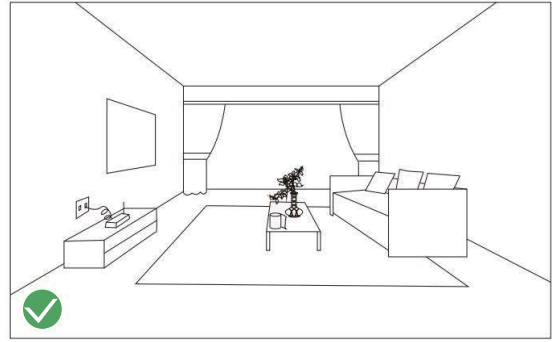
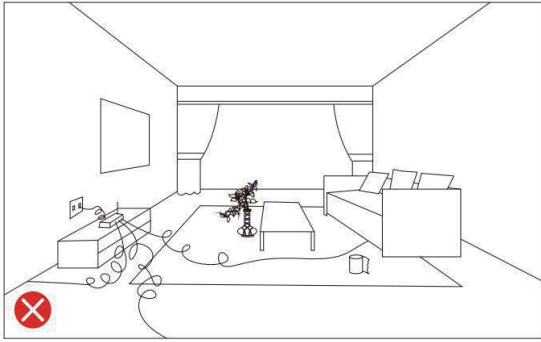

Take away objects such as clothes, loose paper, rope, power line and all fragile objects before using the vacuum cleaning robot. If the robot moves along and pulls out of power line, the line may move objects from table or shelf.

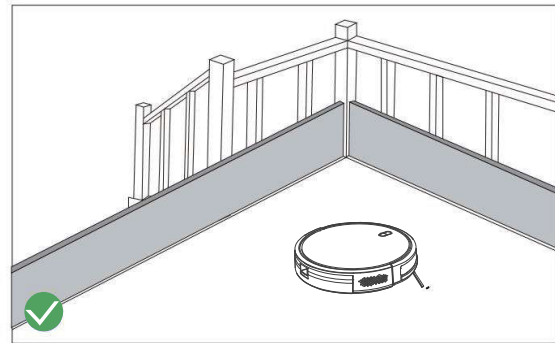
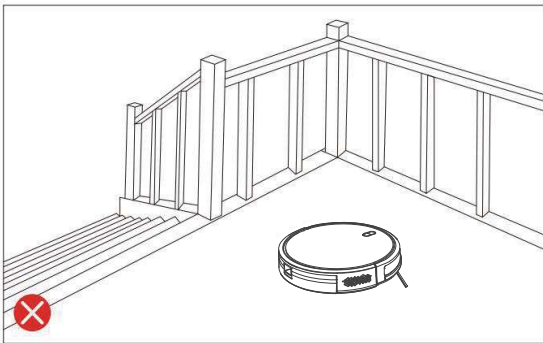

If the room to be cleaned has a balcony, use a barrier to prevent the robot from entering the balcony so as to ensure safety.

## Position of Charging Station

1. The charging station is closed to wall and placed on a flat ground.
2. Ensure the charging station is placed along the wall with no clearance between them.
  - Ensure a free space which is 6.6ft/2m in front of and 3.3ft/1m at both sides of the charging station.

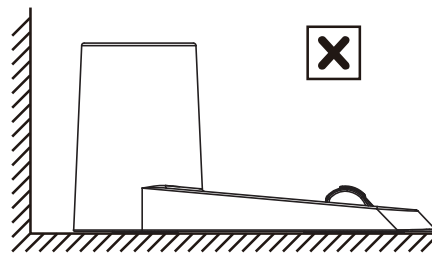
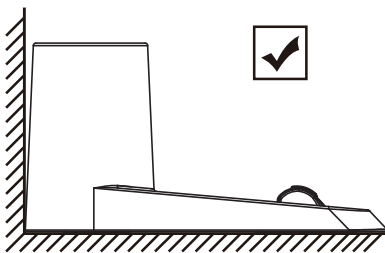

3. Connect plug of the adapter to power socket of charging station and the other end to the socket on the wall.

Tips: Ensure the indicator light is on when the charging station is powered on; otherwise, automatic recharging of the product will fail.

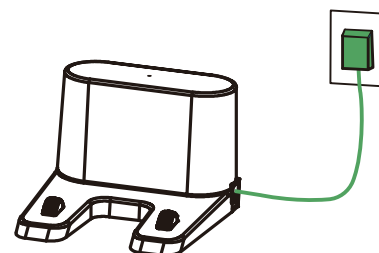
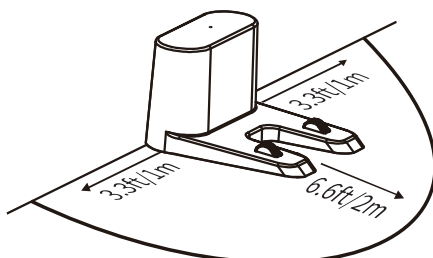





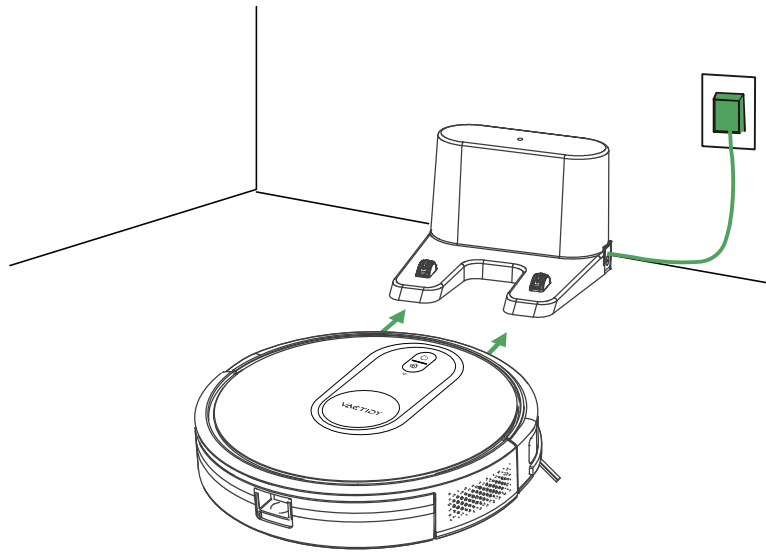

# Product Operation

## Product Activation

Ensure the charging contacts of charging station is well matched with that on the robot. Put the product on charging station. Upon successful activation, the product will give out a series of "Di" sounds. The product can be used once the on/off key light is on.





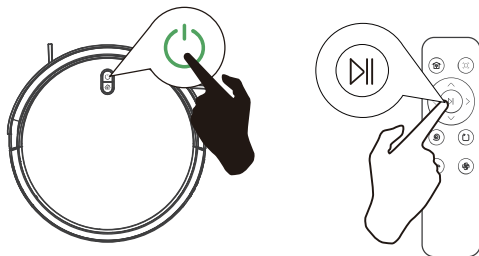

### Start cleaning function

- Long press  to awaken the unit.
- Press  tagain or  on the remote control and the unit will start cleaning automatically.



### Pause

- Press  on the unit or  on remote control to pause the unit that is working.
- Press  on the unit or  on remote control again to continue with cleaning.

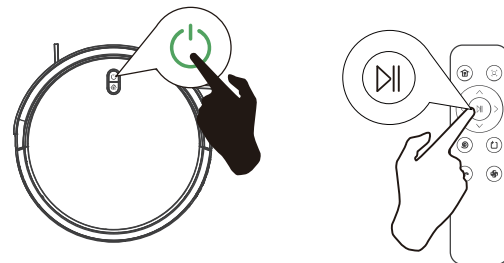

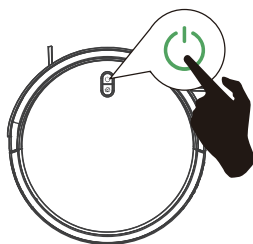

### Shutdown

- Keep pressing  until the unit light is off.



### Recharge

- Press "  " on the main unit, or "  " on the remote control. The machine enters recharge mode.

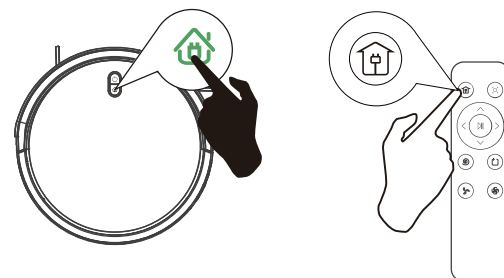

# Product Operation

## Cleaning Modes

### 1. Random cleaning

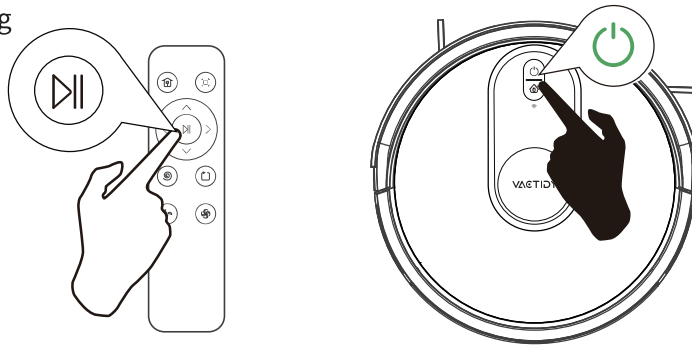

**Tips:** The unit may not find charging station during recharging. If it is the case, the red light of unit will flicker and give out “Di” sound for four times. Please put the unit into charging station manually for charging.

### 2. Spot Cleaning

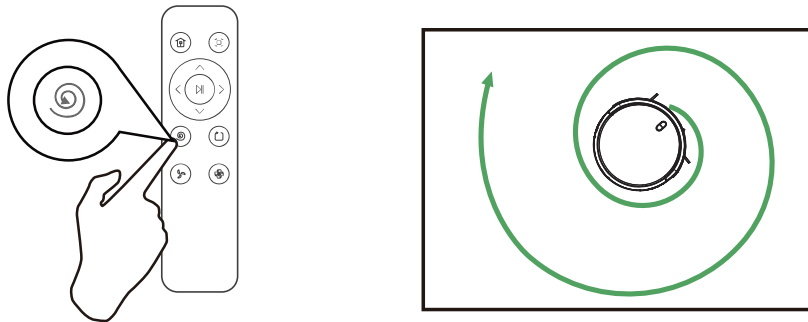

### 3. Edge cleaning

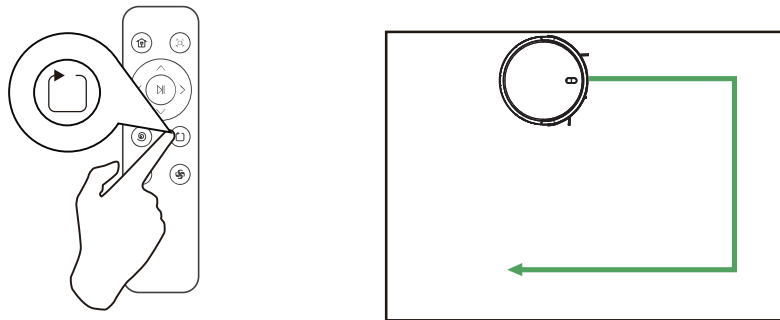

### 4. Room cleaning

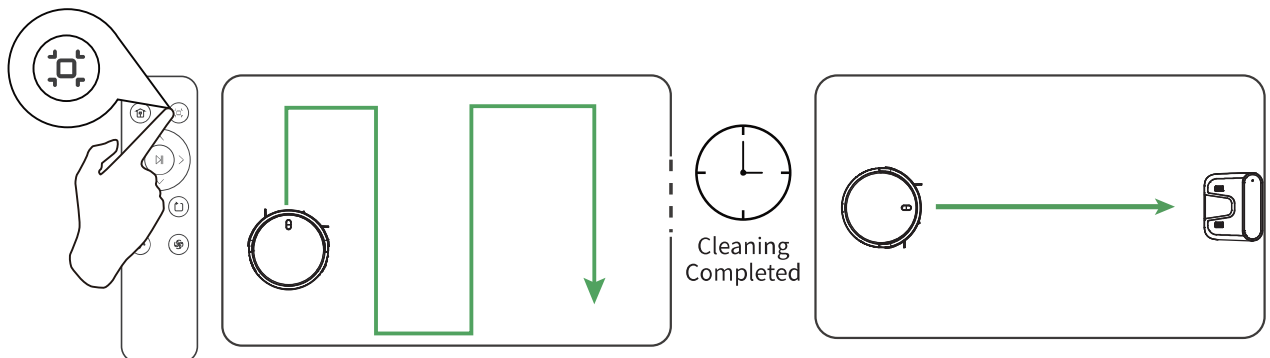

# Product Operation

## Installation of the mopping module

### 1. Installing the mop pad

Attach the washable rag to the mop pad holder attachment area;

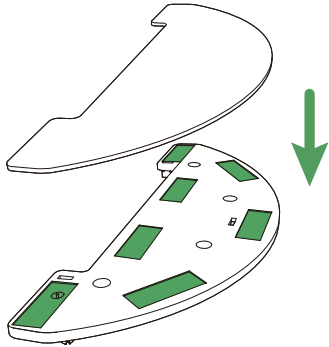

### 2. Fill with water

Open the lid of the 2-in-1 dust box and water tank, fill it with water and close it;

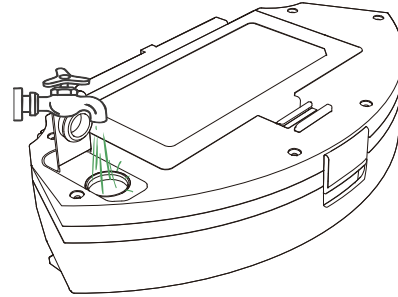

### 3. Install the water tank

Push the 2-in-1 dust box and water tank in horizontally along the slot of the main unit until you hear the "click" sound;

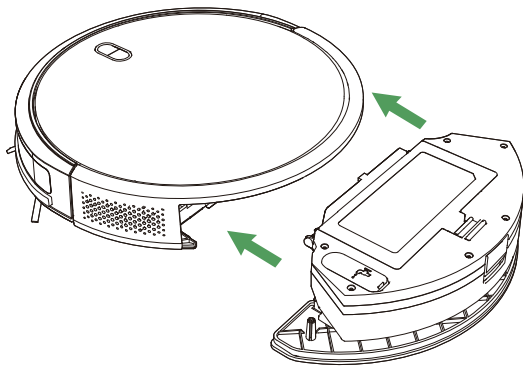

### 4. Installing the mop pad holder

Install the mop holder vertically into the 2-in-1 dust box and water tank until you hear the "click" sound;

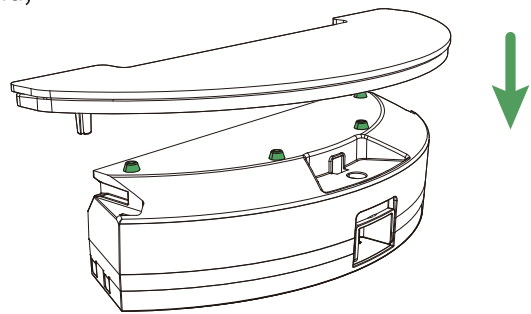

### Note:

1. When cleaning the carpet, please remove the mop pad holder first.
2. Empty the container when the robot has finished wiping.

# Product Operation

## App Connection

To use all available functions, we recommend using the app to control your robot.

## APP Downloading and Installation





1. Download app from the App Store (for iOS) or Google Play (for Android).
2. Open the app and create an account.
3. Tap "+" icon to add "T8" to your account.
4. Follow instructions in the app to set up Wi-Fi connection.

### Before starting, ensure to:

- Connect your phone to a Wi-Fi network.
- Activate the 2.4 GHz band on the router.
- Check whether the wifi indicator light on the robot is flashing .

## Manual Connection

1. Press and hold the “  ” button and the “  ” button for 5 seconds until the indicator light flashes and the network converges.
2. Select the wifi router your phone is connected to, and enter the password.
3. Go to settings and WLAN list to connect to the hotspot "SL-Vactidy-xxxx".
4. Go back to the Vactidy app and complete the wifi connection.

## Connect via Bluetooth

1. Turn on Bluetooth on your phone and scan for nearby Bluetooth devices.
2. Select the robot’s model number.
3. Enter the wifi password to complete the connection.

# Product Maintenance

## Cleaning of Dust Box

1. Press dust box button to take the box out.

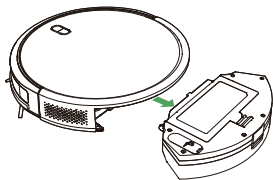

2. Open the cover of dust box to clean it.

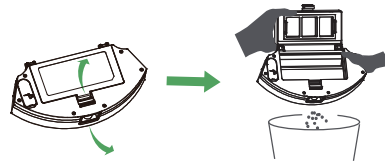

## Filter Cleaning

1. Pull the white label to take out of filter.

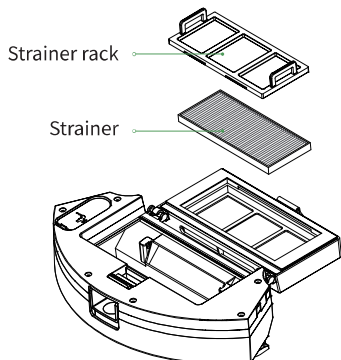

2. Remove the wastes on filter.

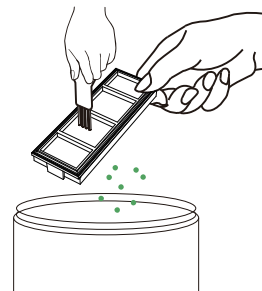

# Product Maintenance

## Cleaning of the Mopping Module

①

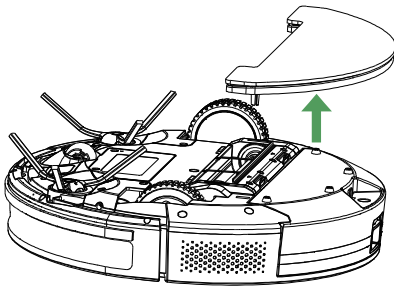

②

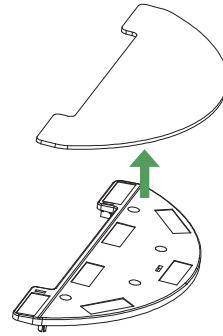

③

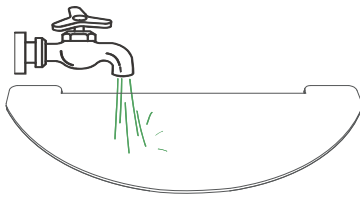

④

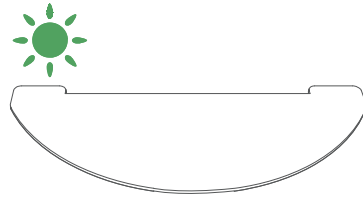

⑤

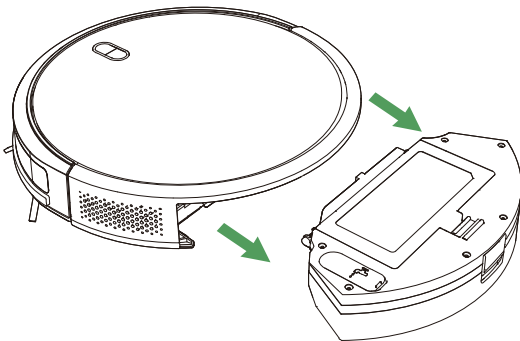

⑥

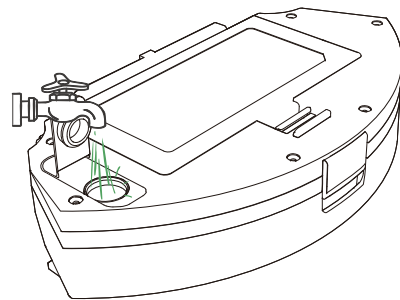

⑦

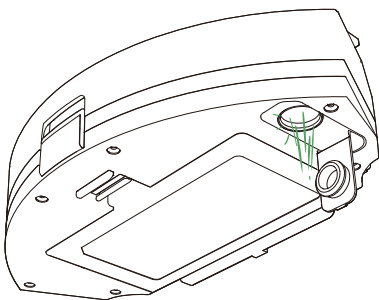

⑧

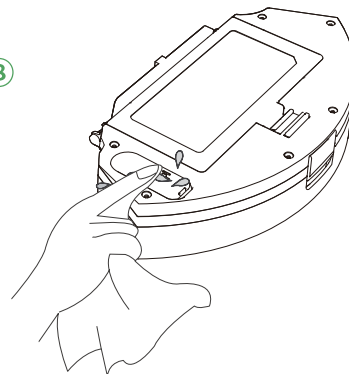

### Note:

Mop and tank water stains need to be dried or wiped dry to avoid mould or odour.

# Product Maintenance

1. Clean the main brush.

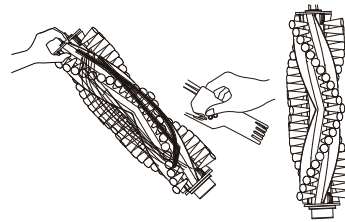
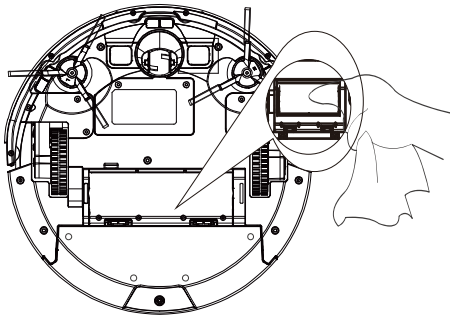
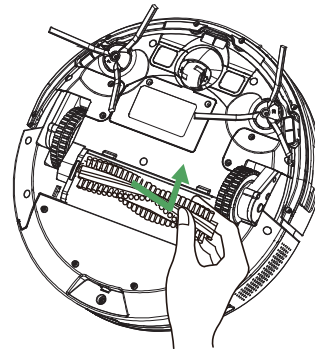
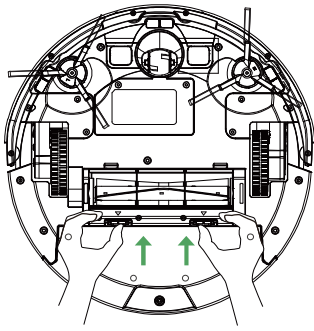

2. Clean the sensors.

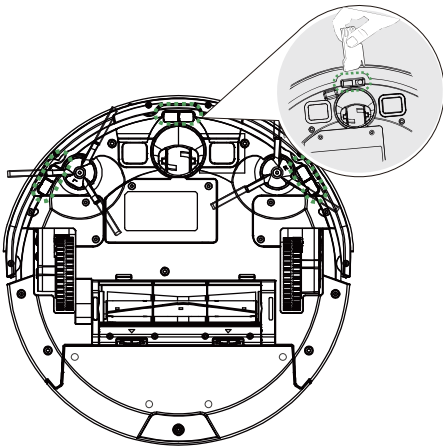

3. Clean the omnidirectional wheel.

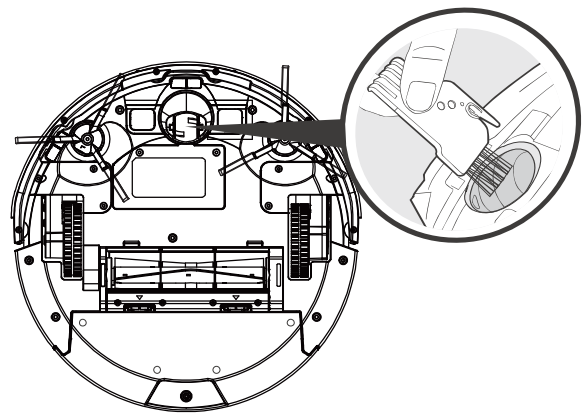

4. Clean the side brush.

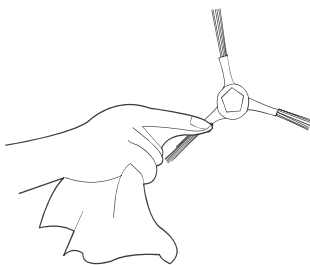

5. Clean the charging station.

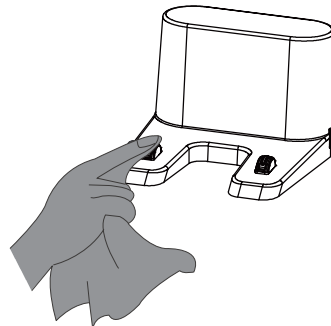

## Product Maintenance

Please clean and maintain the robot parts as per the instructions below in order to ensure the robot's service life and optimal cleaning effect.

### Recommended cleaning/change frequency:

Parts	Cleaning Frequency	Change Frequency
Dust box	After finishing using per time	/
Filter	Once a week	Every 2 months
Main brush	Once a week	Every 6-12 months
Side Brushes	Once a month	Every 3-6 months (or when wearing is serious)
Main brush cover	Once a month	Every 3-6 months (or when wearing is serious)
Sensors	Once a month	/
Charging contacts	Once a month	/
Omnidirectional wheel	Once a month	/

## Product Specifications

Name	Parameters
Model	T8
Rated power	28W
Max. cleaning duration	100min
Charging duration	≤6H



## Troubleshooting

If the robot becomes faulty, LED red light will flicker or be always on and give out “Di” sound. Please confirm and resolve fault of the robot based on the following descriptions of sound and light. If fault cannot be removed by the instructions above, please feel free to contact our customer service specialists.

Robot's Indications		Cause	Solution
The red light is always on	“Di” sound for once	Driving wheels may be stuck by foreign matters	Restart the robot after cleaning the driving wheels
	“Di” sound for twice	Side brushes may be stuck by foreign matters	Restart the robot after cleaning the side brushes
	“Di” sound for three times	Foreign matter may exist in fan	Restart the robot after cleaning dust box and inside of fan
	“Di” sound for four times	Main brush may be stuck by foreign matters	Restart the robot after dismantling and cleaning robot cover and main brush
The red light flickers	“Di” sound for twice	Bumper may be stuck	Touch and press anti-collision beam with hands to see if the left, middle and right sides could bounce automatically
	“Di” sound for three times	Dirt is inside the lower cliff detection sensor of robot or robot is in suspended ground or a dark environment	Clean the lower cliff detection sensor of robot and restart the robot after putting it on a level ground
	“Di” sound for four times	Battery level of robot is low	Charge the robot in charging station

Faults	Solution
Failure to activate robot	<ul style="list-style-type: none"> <li>· Ensure the battery has been fully charged.</li> <li>· Change a pair of AAA batteries for remote control.</li> <li>· Ensure the distance between the remote control and robot is within 0-16ft/0-5m.</li> </ul>
Remote control does not work	<ul style="list-style-type: none"> <li>· Change and install new batteries correctly.</li> <li>· Ensure the power supply of robot has been started and the robot has been fully charged.</li> </ul>
The robot stops working suddenly	<ul style="list-style-type: none"> <li>· Check if the robot is stuck by barriers.</li> <li>· Check battery level.</li> </ul>
The robot fails to do cleaning based on the preset time automatically	<ul style="list-style-type: none"> <li>· Check the status of indicator lamp.</li> </ul>
Weak suction	<ul style="list-style-type: none"> <li>· Check if the suction inlet is blocked by barrier.</li> <li>· Clean dust box.</li> <li>· Clean strainer</li> <li>· Check if strainer is wet. Ensure it has been fully dry prior to use.</li> </ul>
The robot cannot be charged	<ul style="list-style-type: none"> <li>· Check if the socket could supply power and is fully contacted with the charging contacts of charging station. “Bi” sound can be heard under good contact. Wipe charging pole sheet with dry cloth.</li> </ul>

Faults	Solution
The robot cannot come back to charging station	<ul style="list-style-type: none"> <li>· Remove all barriers within 3.3ft/1m at the left and right sides of and 6.6ft/2m in front of the charging station. Place charging station as per the operating instructions. The robot near charging station can return more quickly. If it is far away from the charging station, the robot may return at a low speed so please wait for recharging patiently. The robot will stop immediately if the battery level is too low while searching for recharging. In such a case, the red light will flicker and give out “Di” sound for four times for alarming.</li> </ul>
Main Brush does not rotate	<ul style="list-style-type: none"> <li>· Check if main brush is installed correctly.</li> <li>· Clean main brush.</li> </ul>
The robot follows an abnormal path	<ul style="list-style-type: none"> <li>· Clean bottom view sensor with a dry cloth or swab.</li> <li>· Clean driving wheel.</li> <li>· Touch and press anti-collision beam with hands to see if the left, middle and right sides could bounce automatically.</li> <li>· Turn off power supply and then restart the robot.</li> </ul>

**Shenzhen Jingwu Technology Co., Ltd. (manufacturer)**

Address: 2109,2 dong B zuo ,zhong liang xiang yun, Longcheng street,  
Longgang district, Shenzhen City, China



**WSJ Product LTD**

Unit 1 Alsop Arcade, Brownlow Hill, Liverpool L3 5TX GB



**UE Fast Refund GmbH**

Friedrich-Alfred-Straße 184 Duisburg 47226 Deutschland  
Duisburg 47226 Germany + 49941 7508 3048

**Customer Service**

Email: [support@vactidy.com](mailto:support@vactidy.com)

Europe	North & South America	Japan
+ 44 (0)808 273 7688	+ 1(833) 313 1310	050-5533-2720
Mon-Fri. 9am-5pm (CET)	Mon-Fri. 9am-6pm (ET)	お電話受付時間: 10:30-19:00 (13:30-15:00休み) 営業日:月曜-金曜(土日・祝休)

